

RoHS Compliance

Aluminum oxide Ceramic pad

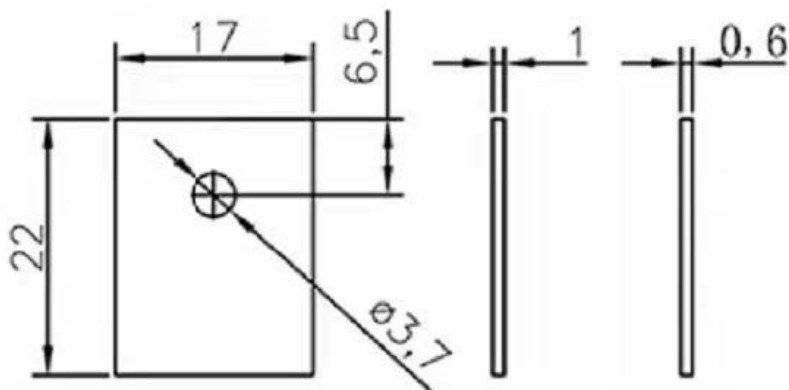

Properties	Unit	96Alumina
Density	g/cm ³	3.65
Water absorption	%	0
Coefficient of Thermal Expansion	10 ⁻⁶ /k	7.9
Modulus of Elasticity Young's Mod	Gpa	280
Poisson's Ratio	/	0.21
HV Hardness	Mpa	1400
Flexural Strength @ Room Temperature	Mpa	280
Flexural Strength @ 700 °C	Mpa	220
Compressive Strength @ Room Temperature	Mpa	2000
Fracture Toughness	Mpa*M0.5	3.8
Heat Conductivity @ Room Temperature	W/m*k	29.3
Electrical Resistivity @ Room Temperature	*mm ² /m	>10 (15)
Max Application Temperature	°C	1500
Resistance to Acid Alkaline	/	High
Dielectric Constant	/	9.5
Dielectric Strength	KV/mm	22.5
Thermal Shock Resistance	T(°C)	220
Tensile Strength @ 25°C	Mpa	200

ANGLE TOLERANCE	PROJECTION	Description:	Thermally conductive pad
±3°		Order number:	AOW TO-247..... 1mm thickness (standard)
			AOW TO-247-0,6.....0,6mm thickness
GENERAL TOLERANCE	UNITS	mm	
x.x ±0.30	SHEET SIZE	A4	PN: AOW TO-247
x.xx ±0.20	Draw:	Daniel	2018-07-10
x.xxx ±0.10	Check:	Daniel	2018-07-10
			Patron Passive Elektronik