

6	EC No.	7	EC Description	8	DR.
	△	/	/	/	/

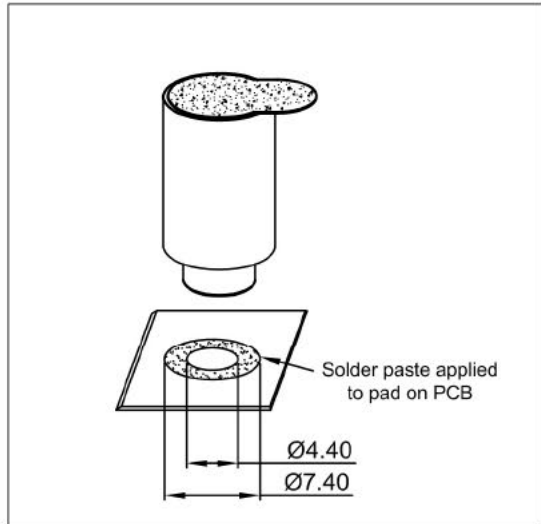
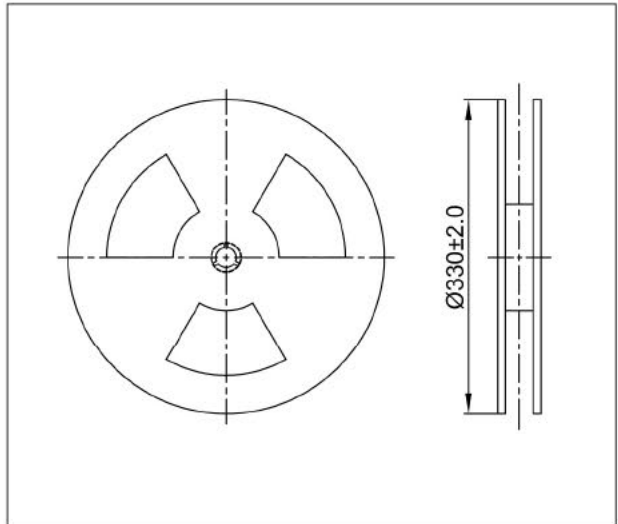
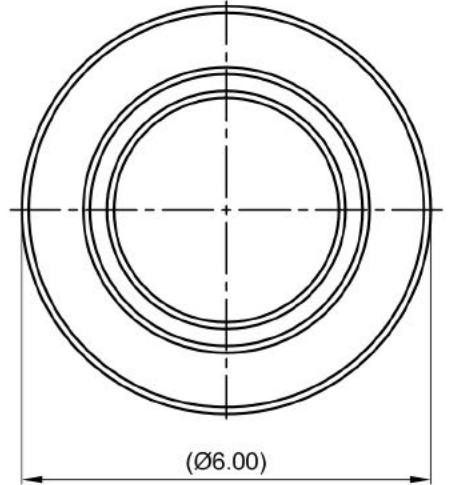
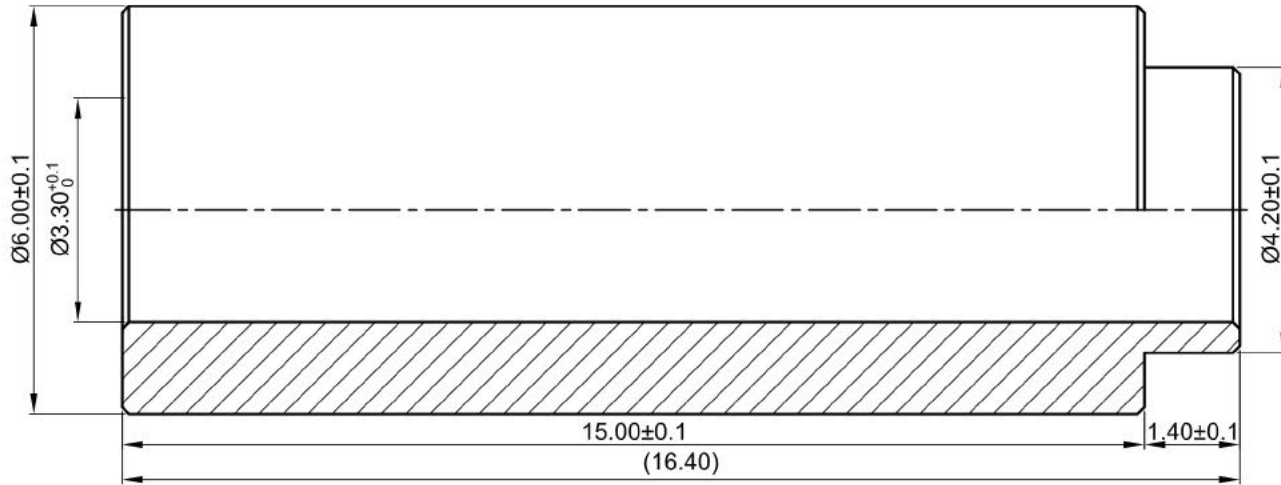

NOTES:
 1.Material:Steel 1215;
 2.Surface Treatment: Tin Plated;
 3.Remove all burrs and sharpe angle ,product is clean;
 4.Packaged on 13" recyclable reels, Tape width is 32mm
 Supplied with polyimide patch for vacuum pick up, Reels conform to IEC 60286-3 Package:250 pcs/Reel;
 5.RoHS Compliant.

UNIT: mm	①	1	/	/	See Note 1	See Note 2	/
	Part Item	QTY.	Name	Description	Material	Surface Treatment	Remark
DIM Tol.: X. ± .X ± .XX ± .XXX ±	DR. LEX 2012.12.06	CHKD.	APPD.	Unit net weight ≈ / g	⊕	⊖	Rough weight ≈ / g
Angle Tol.: X° ± .X° ± .XX° ± .XXX° ±	Patron Passive Electronic			TITLE: SMD Spacer H16.4-OD6.0SDT In/M3 L:15,0mm T&R SPQ:250/R			
				Drawing#: PFPE2878R00	P/N: PFPE2878R00	Version A	Sheet 1 of 1