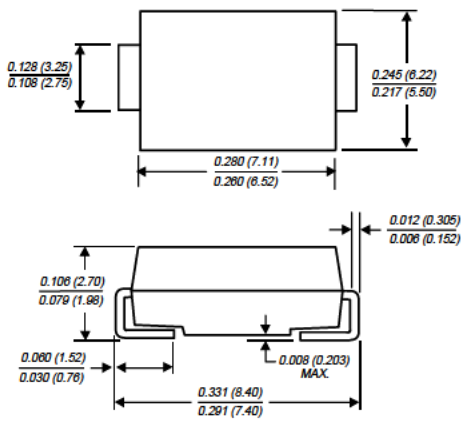

III. Fast / Ultra Fast / Super Fast Recovery Rectifier

3.0A Surface Mount Ultra Fast Recovery Rectifier

US3A~US3M

(Package: SMC (DO-214AB))

<p><u>FEATURES</u></p> <ul style="list-style-type: none"> • For surface mounted applications. • Glass passivated junction chip. • Built-in strain relief, ideal for automated placement. • Plastic material used carries Underwriters Laboratory Flammability Classification 94V-0. • Ultra Fast recovery for high efficiency. • High temperature soldering : 260°C/10 seconds at terminals. <p><u>MECHANICAL DATA</u></p> <ul style="list-style-type: none"> • Case : Molded plastic • Terminals : Solder plated • Polarity : Indicated by cathode band • Weight : 0.220 grams 	 <p>Case: SMC Dimensions in inches and (millimetres)</p>
---	--

Ratings & Electrical Characteristics

Ratings at 25°C ambient temperature unless otherwise specified.

Single phase half-wave 60 Hz, resistive or inductive load, for capacitive load current derate by 20%.

Characteristics	Symbol	US3A	US3B	US3D	US3G	US3J	US3K	US3M	Units
Maximum recurrent peak reverse voltage	V_{RRM}	50	100	200	400	600	800	1000	Volts
Maximum RMS voltage	V_{RMS}	35	70	140	280	420	560	700	Volts
Maximum DC blocking voltage	V_{DC}	50	100	200	400	600	800	1000	Volts
Maximum average forward rectified current See Fig. 1 @ $T_L=110^\circ C$	I_o	3.0							Amps
Peak forward surge current 8.3ms single half sine-wave superimposed on rated load. (JEDEC Method)	I_{FSM}	100							Amps
Maximum instantaneous forward voltage @ 3.0 A	V_F	1.0		1.3		1.7		Volts	
Maximum DC reverse current @ $T_a=25^\circ C$ at rated DC blocking voltage @ $T_a=100^\circ C$	I_R	10.0			250			μA	
Maximum reverse recovery time (Note 1)	T_{rr}	50			75			ns	
Typical junction capacitance (Note 2)	C_j	45			PF				
Typical thermal resistance (Note 3)	R_{th-JA}	25			$^\circ C/W$				
Operating temperature range	T_j	-50 to +150							$^\circ C$
Storage temperature range	T_{stg}	-50 to +150							$^\circ C$

Notes:

1. Reverse recovery test conditions: $I_F=0.5A$, $I_R=1.0A$, $I_{RR}=0.25A$
2. Measured at 1.0 MHz and applied $V_R=4.0V$.
3. Thermal resistance from junction to terminal mounted on 0.6"x0.6" (16x16mm) copper pad areas.

<http://patron-components.com/>

Ratings and Characteristic Curves of US3A~US3M

Fig. 1 FORWARD CURRENT DERATING CURVE

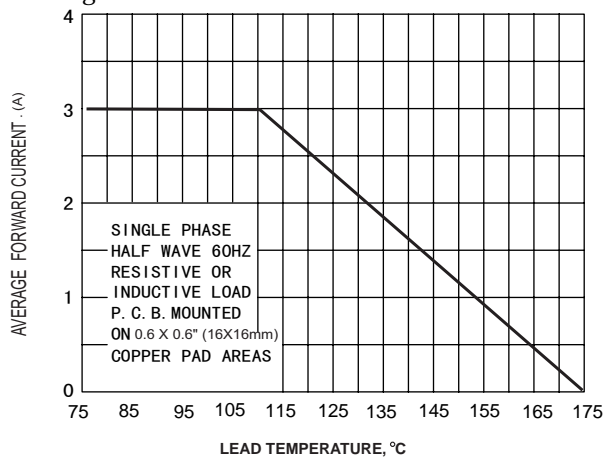

Fig. 2 MAXIMUM NON REPETITIVE PEAK FORWARD SURGE CURRENT

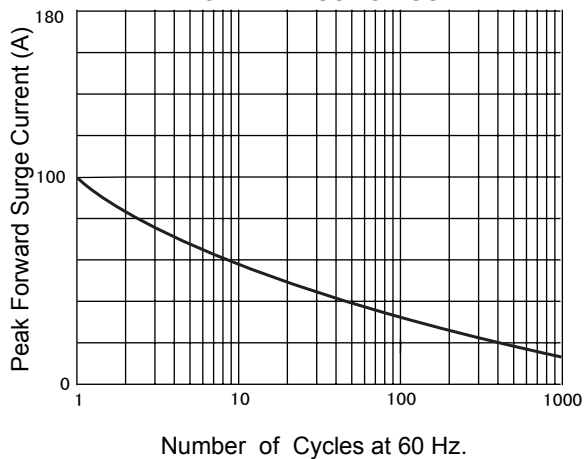

Fig. 3 TYPICAL FORWARD CHARACTERISTIC

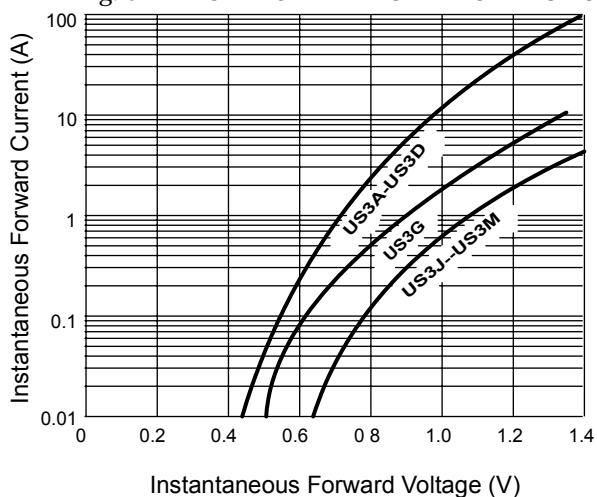

Fig. 4 TYPICAL REVERSE CHARACTERISTIC

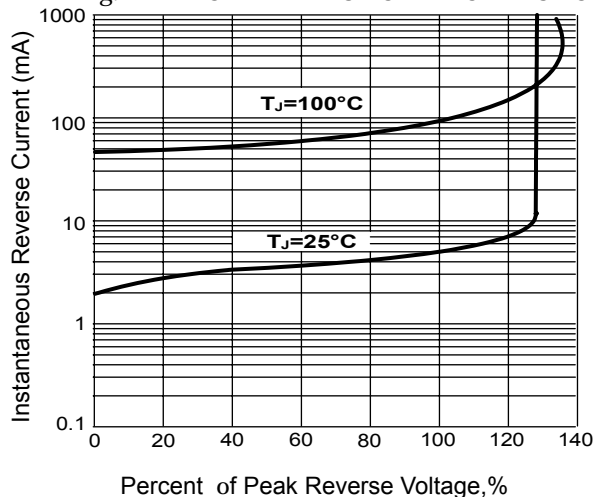

Fig. 5 TYPICAL JUNCTION CAPACITANCE

