

## V. Transient Voltage Suppressor

### 400W Surface Mount TVS (Stand-off Voltage: 5.0~440 Volts)

### SMAJ Series

(Package: SMA (DO-214AC))

#### FEATURES

- Optimized for LAN protection applications.
- Ideal for ESD protection of data lines in accordance with IEC 1000-4-2(IEC801-2).
- Ideal for EFT protection of data lines in accordance with IEC 1000-4-4(IEC801-2).
- Plastic package has Underwriters Laboratory Flammability Classification 94V-0.
- Glass passivated junction.
- 400W peak pulse power capability.
- Excellent clamping capability.
- Low incremental surge resistance.
- Fast response time: typically less than 1.0ps from 0v to  $V_{(BR)}$  min.
- High temperature soldering guaranteed: 250 /10s at terminals.

#### MECHANICAL DATA

- Case : JEDEC DO-214AC molded plastic body over passivated junction.
- Terminals : Solder plated, solderable per MIL-STD-750, method 2026
- Polarity : Color band denotes cathode except for bi-directional types.
- Mounting Position : Any
- Weight : 0.058 grams

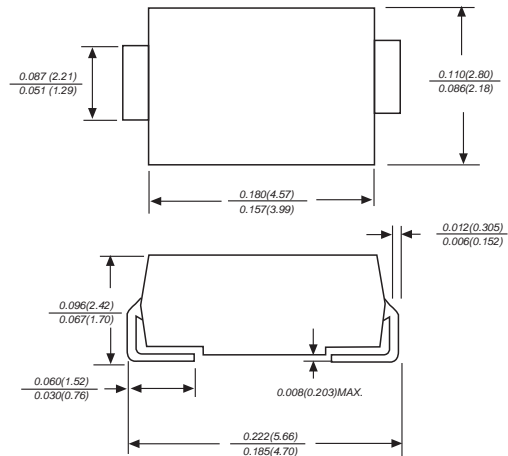

Case: SMA  
Dimensions in inches and (millimetres)

### Devices for Bi-Directional Applications

For bi-directional devices, use suffix "CA" for types SMAJ5.0CA thru SMAJ440CA (e.g. SMAJ10CA). Electrical characteristics apply in both directions.

### Maximum Ratings, Thermal & Electrical Characteristics

(Ratings at 25 ambient temperature unless otherwise specified)

Ratings	Symbol	Value	Units
Peak power dissipation with a 10/1000µs waveform <sup>(1) (2)</sup> (see Fig. 1)	$P_{PPM}$	Minimum 400	Watts
Peak pulse current with a 10/1000µs waveform <sup>(1)</sup>	$I_{PPM}$	See Table 1	Amps
Steady state power dissipation <sup>(3)</sup>	$P_{M(AV)}$	1.0	Watts
Peak forward surge current <sup>(4)</sup>	$I_{FSM}$	40	Amps
Maximum instantaneous forward voltage at 25 A <sup>(4)</sup>	$V_F$	3.5	Volts
Operating junction and storage temperature range	$T_j, T_{stg}$	-55 to +150	

Note:

1. Non-repetitive current pulse, per Fig.3 and derated above  $T_a = 25$  per Fig.2.
2. Mounted on 5.0 x 5.0 mm copper pads to each terminal.
3. Lead Temperature at  $T_L = 75$  per Fig. 5.
4. Measured on 8.3ms single half sine-wave for uni-directional devices only.

## V. TVS & Overvoltage Protection Device

### 400W Surface Mount TVS (Stand-off Voltage: 5.0~440 Volts) SMAJ Series (Package: SMA (DO-214AC))

Device Type	Device Marking Code			Breakdown Voltage $V_{(BR)}$ @ $I_T$			Maximum Reverse Leakage $I_R(\mu A)$ @ $V_{WM}$	Stand-off Voltage $V_{WM}$ (Volts)	Maximum Peak Pulse Current $I_{PPM}(A)$	Maximum Clamping Voltage $V_C$ (Volts) @ $I_{PPM}$
	Option 1	Option 2		Min (V)	Max (V)	$I_T$ (mA)				
	Full Part Number	Uni	Bi							
SMAJ5.0(C)A	Full PN	AE	WE	6.40	7.00	10	800	5.0	43.5	9.20
SMAJ6.0(C)A	Full PN	AG	WG	6.67	7.37	10	800	6.0	38.8	10.3
SMAJ6.5(C)A	Full PN	AK	WK	7.22	7.98	10	500	6.5	35.7	11.2
SMAJ7.0(C)A	Full PN	AM	WM	7.78	8.60	10	200	7.0	33.3	12.0
SMAJ7.5(C)A	Full PN	AP	WP	8.33	9.21	1	100	7.5	31.0	12.9
SMAJ8.0(C)A	Full PN	AR	WR	8.89	9.83	1	50	8.0	29.4	13.6
SMAJ8.5(C)A	Full PN	AT	WT	9.44	10.4	1	20	8.5	27.8	14.4
SMAJ9.0(C)A	Full PN	AV	VV	10.0	11.1	1	10	9.0	26.0	15.4
SMAJ10(C)A	Full PN	AX	WX	11.1	12.3	1	5.0	10	23.5	17.0
SMAJ11(C)A	Full PN	AZ	WZ	12.2	13.5	1	5.0	11	22.0	18.2
SMAJ12(C)A	Full PN	BE	XE	13.3	14.7	1	5.0	12	20.1	19.9
SMAJ13(C)A	Full PN	BG	XG	14.4	15.9	1	5.0	13	18.6	21.5
SMAJ14(C)A	Full PN	BK	XK	15.6	17.2	1	5.0	14	17.2	23.2
SMAJ15(C)A	Full PN	BM	XM	16.7	18.5	1	5.0	15	16.4	24.4
SMAJ16(C)A	Full PN	BP	XP	17.8	19.7	1	5.0	16	15.4	26.0
SMAJ17(C)A	Full PN	BR	XR	18.9	20.9	1	5.0	17	14.5	27.6
SMAJ18(C)A	Full PN	BT	XT	20.0	22.1	1	5.0	18	13.7	29.2
SMAJ20(C)A	Full PN	BV	XV	22.2	24.5	1	5.0	20	12.3	32.4
SMAJ22(C)A	Full PN	BX	XX	24.4	26.9	1	5.0	22	11.3	35.5
SMAJ24(C)A	Full PN	BZ	XZ	26.7	29.5	1	5.0	24	10.3	38.9
SMAJ26(C)A	Full PN	CE	YE	28.9	31.9	1	5.0	26	9.5	42.1
SMAJ28(C)A	Full PN	CG	YG	31.1	34.4	1	5.0	28	8.8	45.4
SMAJ30(C)A	Full PN	CK	YK	33.3	36.8	1	5.0	30	8.3	48.4
SMAJ33(C)A	Full PN	CM	YM	36.7	40.6	1	5.0	33	7.5	53.3
SMAJ36(C)A	Full PN	CP	YP	40.0	44.2	1	5.0	36	6.9	58.1
SMAJ40(C)A	Full PN	CR	YR	44.4	49.1	1	5.0	40	6.2	64.5
SMAJ43(C)A	Full PN	CT	YT	47.8	52.8	1	5.0	43	5.8	69.4
SMAJ45(C)A	Full PN	CV	YV	50.0	55.3	1	5.0	45	5.5	72.7
SMAJ48(C)A	Full PN	CX	YX	53.3	58.9	1	5.0	48	5.2	77.4
SMAJ51(C)A	Full PN	CZ	YZ	56.7	62.7	1	5.0	51	4.9	82.4
SMAJ54(C)A	Full PN	RE	ZE	60.0	66.3	1	5.0	54	4.6	87.1
SMAJ58(C)A	Full PN	RG	ZG	64.4	71.2	1	5.0	58	4.3	93.6
SMAJ60(C)A	Full PN	RK	ZK	66.7	73.7	1	5.0	60	4.1	96.8
SMAJ64(C)A	Full PN	RM	ZM	71.1	78.6	1	5.0	64	3.9	103
SMAJ70(C)A	Full PN	RP	ZP	77.8	86.0	1	5.0	70	3.5	113
SMAJ75(C)A	Full PN	RR	ZR	83.3	92.1	1	5.0	75	3.3	121
SMAJ78(C)A	Full PN	RT	ZT	86.7	95.8	1	5.0	78	3.2	126
SMAJ85(C)A	Full PN	RV	ZV	94.4	104	1	5.0	85	2.9	137
SMAJ90(C)A	Full PN	RX	ZX	100	111	1	5.0	90	2.7	146
SMAJ100(C)A	Full PN	RZ	ZZ	111	123	1	5.0	100	2.5	162
SMAJ110(C)A	Full PN	SE	VE	122	135	1	5.0	110	2.3	177
SMAJ120(C)A	Full PN	SG	VG	133	147	1	5.0	120	2.1	193
SMAJ130(C)A	Full PN	SK	VK	144	159	1	5.0	130	1.9	209
SMAJ150(C)A	Full PN	SM	VM	167	185	1	5.0	150	1.6	243
SMAJ160(C)A	Full PN	SP	VP	178	197	1	5.0	160	1.5	259
SMAJ170(C)A	Full PN	SR	VR	189	209	1	5.0	170	1.5	275
SMAJ180(C)A	Full PN	ST	VT	201	222	1	5.0	180	1.4	292
SMAJ200(C)A	Full PN	SV	VV	224	247	1	5.0	200	1.2	324
SMAJ220(C)A	Full PN	SX	VX	246	272	1	5.0	220	1.1	356
SMAJ250(C)A	Full PN	SZ	VZ	279	309	1	5.0	250	1.0	405
SMAJ300(C)A	Full PN	TE	UE	335	371	1	5.0	300	0.8	486
SMAJ350(C)A	Full PN	TG	UG	391	432	1	5.0	350	0.7	567
SMAJ400(C)A	Full PN	TK	UK	447	494	1	5.0	400	0.6	648
SMAJ440(C)A	Full PN	TM	UM	492	543	1	5.0	440	0.6	713

Note:

1.  $V_{(BR)}$  measured after  $I_T$  applied for 300us,  $I_T$  = square wave pulse or equivalent
2. Surge current waveform per Fig. 3 and derate per Fig. 2
3. For bi-directional types having  $V_{WM}$  of 10 Volts and less, the  $I_R$  limit is doubled
4. All terms and symbols are consistent with ANSI/IEEE C62.35

# Ratings and Characteristic Curves of SMAJ Series

FIG. 1-PEAK PULSE POWER RATING CURVE

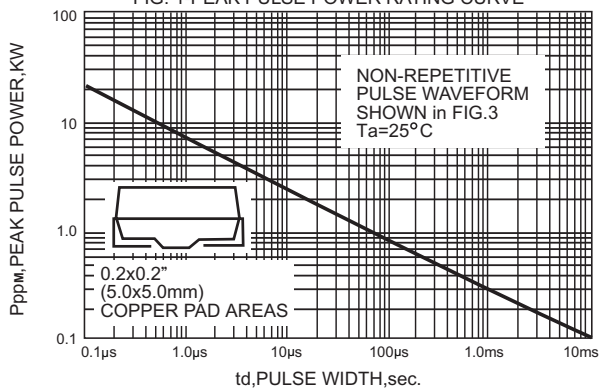

FIG. 2-PULSE DERATING CURVE

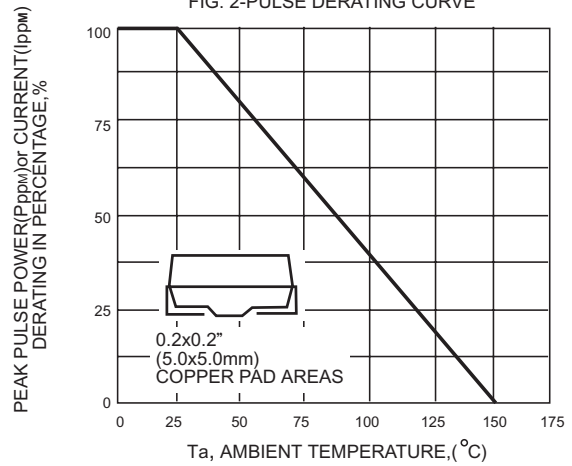

FIG.3-PULSE WAVEFORM

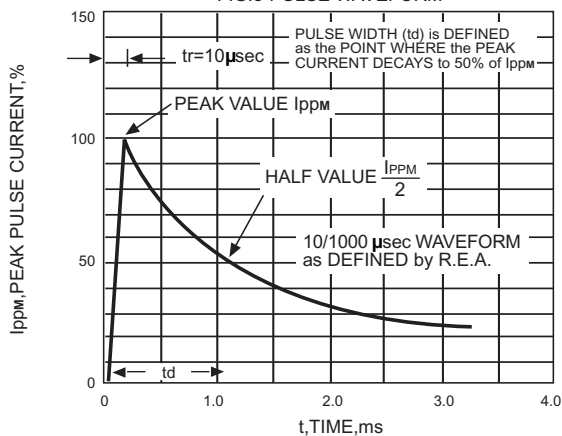

FIG. 4-TYPICAL JUNCTION CAPACITANCE UNIDIRECTIONAL

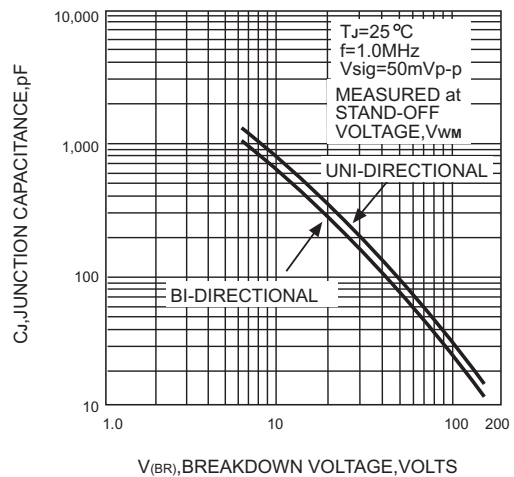

FIG.5-STEADY STATE POWER DERATING CURVE

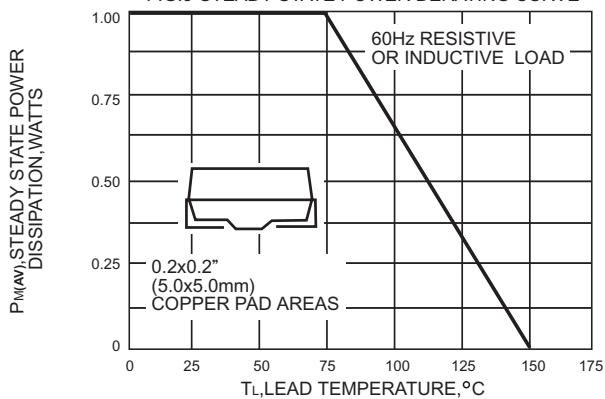

FIG.7-TYPICAL RESPONSE TO 8KV POSITIVE GOLING ESD PULSE PER IEC1000-4-2(IEC801-2)

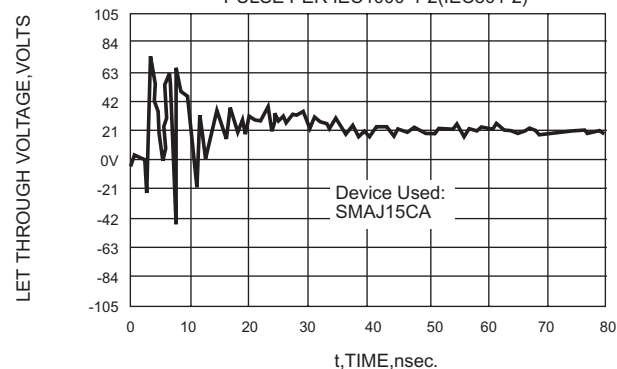

FIG.6-MAXIMUM NON-REPETITIVE FORWARD SURGE CURRENT UNIDIRECTIONAL ONLY

