

Appendix

General packing information for Axial Devices

Tape in Box Packing Details

TAPE IN BOX SPECIFICATIONS			
Description	Symbol	Body	Specification (mm)
Component Pitch	A	DO-15, DO-35, DO-41, R1	5.0 ± 0.5
		DO-201, DO-201AD, R-6	10.0 ± 0.5
Inside Tape Spacing	B	All	52.4 ± 1.5
Lead to Lead Eccentricity	D ₁ - D ₂	All	1.4 max
Lead Extension	K	All	0.8 max
Lead Bending	M	All	1.2 max
Cumulative Pitch	P	All	±1.5 per 6 pitch
Exposed Adhesive	S	All	0.8 max
Tape Width	T	All	6.0 ± 0.4
Empty Spaces			< 0.1%
Polarity Marking	All polarized components shall be oriented in the same direction. The cathode tape shall be colored, and the anode tape shall be white or light beige.		

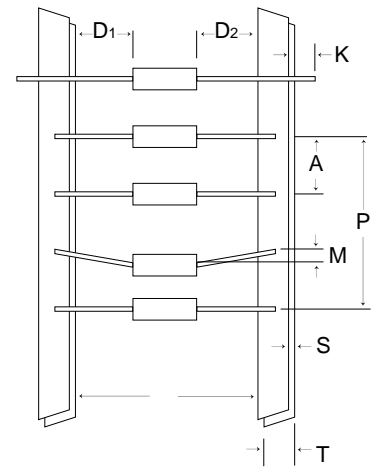

Dimensions A, M, K, P, S & T apply to both sides

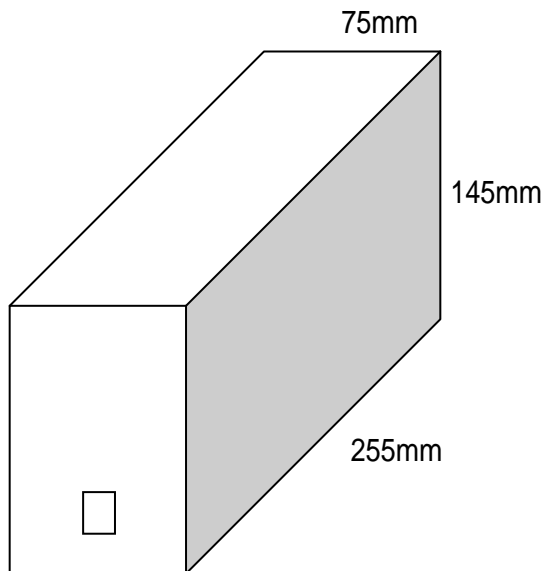

Product Type	Qty / Box
DO-41 (Plastic Case)	5000
DO-15	2500
DO-201AD	1250
DO-201AE	1250
R6	500

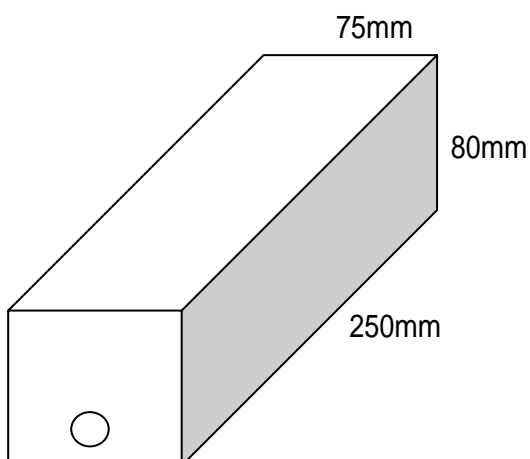

Product Type	Qty / Box
R1	5000
DO-35	5000
DO-41 Glass case	2500