



### DESCRIPTION: 5W 4KVAC Isolation Wide Input AC/DC Converters

The rated output power of PP05AC series is 5W with wide input voltage range, for both AC input and DC input application. High reliability, precision, large power density, ultra-small size, no external heat sink required, stable output voltage and etc, with over current protection, EMI filter circuit, the rectifier filter circuit, 4000V isolation voltage, short circuit, overload, internal thermal protection. Widely used in telecommunications, industrial control, instrument, data acquisition, signal control and other electronic systems.

### FEATURES

Universal input voltage range	AC and DC dual-use	Wide input voltage: 4:1
Fixed switching frequency	Overheat protection	Over current protection
Short circuit protection	RoHS compliant	Operating temperature: -40°C to 70°C

### SELECTION GUIDE

Part Number	Input		Output		Efficiency (Typ. ) %
	Voltage (VAC)		Voltage (VDC)	Current (A)	
	Voltage VAC	Voltage VDC			
PP05AC220S05W	85-300	110-370	5	1.00	69
PP05AC220S09W	85-300	110-370	9	0.55	73
PP05AC220S12W	85-300	110-370	12	0.42	75
PP05AC220S15W	85-300	110-370	15	0.33	76
PP05AC220S24W	85-300	110-370	24	0.23	78

All specifications typical at TA=25°C, nominal input voltage and rated output current unless otherwise specified.

### INPUT SPECIFICATIONS

Parameter	Conditions	Min.	Typ.	Max.	Units
Input Voltage Range	DC input	110	220	375	VDC
Input Voltage Range	AC input	85	220	300	VAC
Input Frequency		47		63	HZ
Input Current	110VAC			150	mA
Input Current	230VAC			70	mA
Inrush Current	110VAC		10		A
Inrush Current	230VAC		20		A
Recommended External Input Fuse(Special package series include fuse)		1A/250V, slow fusing, necessary			
Hot Plug		Unavailable			

### OUTPUT SPECIFICATIONS

Parameter	Conditions	Min.	Typ.	Max.	Units
Output Voltage Accurac				±2	%
Line Regulation	Full load		±0.5		%
Load Regulation	10%-100% load		±1		%
Short Circuit Protection		Hiccup, continuous, self-recovery			
Ripple & Noise	20MHz bandwidth (peak-peak value)		50	100	mv
Temperature Coefficient			±0.02		%/°C
Stand-by Power Consumption				0.3	W
Over-current Protection		≥110%lo self-recovery			
Over-voltage Protection		Over-voltage shutdown			
Hold-up Time	110VAC input		12		ms
Hold-up Time	230VAC input		80		ms

## ENVIRONMENT CHARACTERISTICS

Parameter	Conditions	Min.	Typ.	Max.	Units
olation Voltage Input-output	Test time: 1min	4000			VAC
Operating Temperature		-40		+70	°C
Storage Temperature		-40		+85	°C
Storage Humidity				85	% .RH max
Switching Frequency				140	kHz
Power Derating	+55°C~+70°C	2.0			%/°C
Power Derating	+0°C~+25°C	2.0			%/°C
MTBF		MIL-HDBK-217F@25°C > 300,000 h			

- Case temperature shall not exceed the maximum case temperature.

## EMC SPECIFICATIONS

EMI	CE	CISPR22/EN55022, CLASS B
EMI	RE	CISPR22/EN55022, CLASS B
EMS	ESD	IEC/EN61000-4-2 ±6KV/8KV perf. Criteria B
EMS	RS	IEC/EN61000-4-3 10V/m perf. Criteria A
EMS	EFT	IEC/EN61000-4-4 ± 2kV perf. Criteria B
EMS	EFT	IEC/EN61000-4-4 ± 4kV (See Fig. 2 for recommended circuit) perf. Criteria B
EMS	Surge	IEC/EN61000-4-5 ±1KV perf. Criteria B
EMS	Surge	IEC/EN61000-4-5 ±2KV/±4KV (See Fig. 2 for recommended circuit) perf. Criteria B
EMS	CS	IEC/EN61000-4-6 10 Vr.m.s perf. Criteria A
EMS	PFM	IEC/EN61000-4-8 10A/m perf. Criteria A
EMS	Voltage dips, short interruptions and voltage variations immunity	IEC/EN61000-4-11 0%-70% perf. Criteria B

## DESIGN REFERENCE

### 1、 Typical application circuit

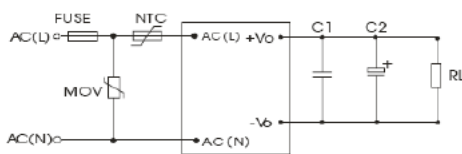

Fig.1

Model	C1(μF)	C2(μF)
PP05AC220S05W	1	220
PP05AC220S09W	1	220
PP05AC220S12W	1	100
PP05AC220S15W	1	100
PP05AC220S24W	1	47

Note: Output filtering capacitor C2 is a electrolytic capacitor, it is recommended to use high frequency and low impedance electrolytic capacitor. For capacitance and current of capacitor please refer to manufacture's datasheet. Output capacitor withstand voltage derating should be 80% or above. C1 is ceramic capacitor, which is used to filter high-frequency noise. External input NTC is recommended to use 12D-5; External input MOV is recommended to use S14K350.

### 2、 EMC solution-recommended circuit

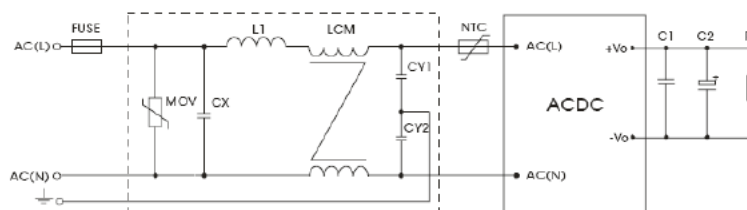
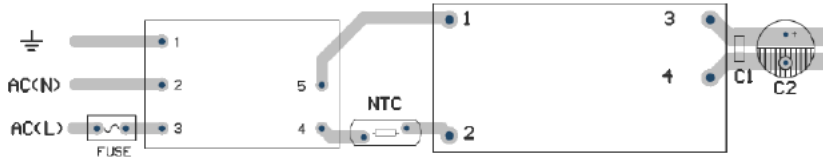

Fig.2

## DESIGN REFERENCE

EMC solution-recommended circuit PCB layout



Note: Suggestions for safety regulation and wiring width: wire width  $\geq 3\text{mm}$ , distance between wires  $\geq 6\text{mm}$ , and distance between wire and ground  $\geq 6\text{mm}$

Element model	Recommended value C2( $\mu\text{F}$ )
MOV	14D561K
CX	0.1 $\mu\text{F}$ /275VAC
L1	4.7 $\mu\text{H}$ /2.0A
CY1	1nF/400VAC
CY2	1nF /400VAC
LCM	2.2mH
FUSE	1A/250V, slow fusing, necessary

## MECHANICAL DIMENSIONS

DIP Package

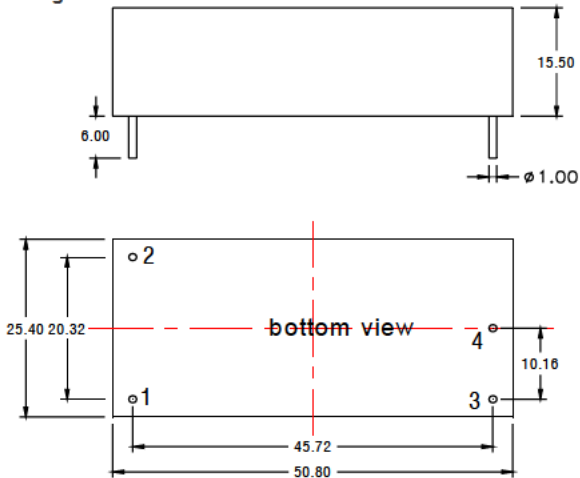

Units:mm

Tolerance: $\pm 0.2\text{mm}$

## PIN CONNECTIONS

Pin	Single output
1	N
2	L
3	+V0
4	-V0

## MODEL SELECTION

