



DESCRIPTION: 30W 1.5KVDC Isolated Wide Voltage Input DC/DC Converters

The rated output power of PP30DG converters is 30W, 2:1 and 4:1 wide input voltage range ,the voltage range is 9V-18V,18V-36V,36V-72V,9V-36V and 18V-72VDC.The accuracy of the converter can reach $\pm 1\%$,It can be widely used in telecommunications ,railway transportation, instrument and etc.

FEATURES

30W output power	2:1 and 4:1 wide input voltage range	Long term short-circuit protection
1.5KVDC isolation	Input under voltage protection	Super capability with capacitive load
Fixed switching frequency	Operating temperature: -40°C to 85°C	Metal shielding package
RoHs compliance	/	/

SELECTION GUIDE

Part Number	Input Voltage		Output		Efficiency(Typ.) %
	voltage (VDC)		Voltage (VDC)	Current (A)	
	Rated	Range values			
PP30DG12S03	12(2:1)	9-18	3.3	6	85
PP30DG12S05	12(2:1)	9-18	5	6	83
PP30DG12S12	12(2:1)	9-18	12	2.5	86
PP30DG12S15	12(2:1)	9-18	15	2	86
PP30DG12S24	12(2:1)	9-18	24	1.25	85
PP30DG12D05	12(2:1)	9-18	± 5	± 3	83
PP30DG12D12	12(2:1)	9-18	± 12	± 1.25	86
PP30DG24S03	24(2:1)	18-36	3.3	6	85
PP30DG24S05	24(2:1)	18-36	5	6	84
PP30DG24S12	24(2:1)	18-36	12	2.5	87
PP30DG24S15	24(2:1)	18-36	15	2	87
PP30DG24S24	24(2:1)	18-36	24	1.25	86
PP30DG24D05	24(2:1)	18-36	± 5	± 3	83
PP30DG24D12	24(2:1)	18-36	± 12	± 1.25	86
PP30DG24D15	24(2:1)	18-36	± 15	± 1	86
PP30DG48S03	48(2:1)	36-72	3.3	6	85
PP30DG48S05	48(2:1)	36-72	5	6	84
PP30DG48S12	48(2:1)	36-72	12	2.5	87
PP30DG48S15	48(2:1)	36-72	15	2	87
PP30DG48S24	48(2:1)	36-72	24	1.25	86
PP30DG48D05	48(2:1)	36-72	± 5	± 3	83
PP30DG48D12	48(2:1)	36-72	± 12	± 1.25	86
PP30DG48D15	48(2:1)	36-72	± 15	± 1	86
PP30DG24S05W	24(4:1)	9-36	5	6	81
PP30DG24S12W	24(4:1)	9-36	12	2.5	85
PP30DG24S15W	24(4:1)	9-36	15	2	85
PP30DG24S24W	24(4:1)	9-36	24	1.25	85
PP30DG24D05W	24(4:1)	9-36	± 5	± 3	81
PP30DG24D12W	24(4:1)	9-36	± 12	± 1.25	84
PP30DG24D15W	24(4:1)	9-36	± 15	± 1	84
PP30DG48S05W	48(4:1)	18-72	5	6	81
PP30DG48S12W	48(4:1)	18-72	12	2.5	85
PP30DG48S15W	48(4:1)	18-72	15	2	85
PP30DG48S24W	48(4:1)	18-72	24	1.25	85
PP30DG48D05W	48(4:1)	18-72	± 5	± 3	81
PP30DG48D12W	48(4:1)	18-72	± 12	± 1.25	84
PP30DG48D15W	48(4:1)	18-72	± 15	± 1	84

Input voltage 9-18VDC , start-up voltage 9.5-18VDC , input voltage 9-36VDC ,start-up voltage 9.5-36VDC.

All specifications typical at TA=25°C, nominal input voltage and rated output current unless otherwise specified.

GENERAL CHARACTERISTICS

parameter	Test conditions	Min	Typ	Max	Units
Isolation voltage	Input to output		500	1500	VDC
Insulation resistance	Input to output	100M			Ohm
Seismic	10~55Hz		5		G
MTBF	MIL-HDBK-217F2		5*10 ⁵		hrs
Over-current protection mode	All input range	Burp, Automatic recovery			
Cooling	Free air convection				
Case material	Metal case				

INPUT CHARACTERISTICS

parameter	Test conditions	Min	Typ	Max	Units
Input voltage	12V Input module(9V-18V)	9.5	12	18	VDC
Input voltage	24V Input module(18V-36V)	18	24	36	VDC
Input voltage	48V Input module(36V-72V)	36	48	72	VDC
Input voltage	24V Input module(9V-36V)	9.5	24	36	VDC
Input voltage	48V Input module(18V-72V)	18	48	72	VDC
Startup time	Output rise time from 5% to 100%	20			ms
Remote control CTL	Remote CTL-Vin	Turn off			
Remote control CTL	Remote CTL NC(The control level 12V-40V)	Turn on			

OUTPUT CHARACTERISTICS

parameter	Test conditions	Min	Typ	Max	Units
Voltage accuracy	$I_o=0.1 \dots 1.0 \times I_{onom}$ $V_i=V_i$ rated			±1	%
Line regulation	$V_{imin} \leq V_i \leq V_{imax}$			±0.2	%
Load regulation	$I_o=0.1 \dots 1.0 \times I_{onom}$ $V_{imin} \leq V_i \leq V_{imax}$			±0.5	%
Auxiliary voltage accuracy	Main Load and auxiliary load differ 25%,the auxiliary circuit of the load carrying at least 25%, the main circuit running the full load			±3	%
Ripple and noise	20MHz bandwidth			±1	%
Over-current protection	$V_{imin} \leq V_i \leq V_{imax}$	120			%
Output voltage trim range	$V_{imin} \leq V_i \leq V_{imax}$			10	%
Transient recovery time	25% load changes			±5	%
Transient overshoot time	25% load changes			400	us
Switch frequency	$V_{imin} \leq V_i \leq V_{imax}$		300		KHz

ENVIRONMENT CHARACTERISTICS

parameter	Test conditions	Min	Typ	Max	Units
Storage Humidity	Non condensing	5		+95	%
Operating Temperature	Power derating (above 71℃)	-40		+85	℃
Storage Temperature		-55		+125	℃
Max. Case Temperature	Operating Temperature curve range			105	℃
Lead Temperature	1.5mm from case for 10 seconds			300	℃
Cooling	Free air convection				

- Module in every environment temperature rating, case temperature under shall not exceed the maximum case temperature level.

MECHANICAL DIMENSIONS

DIP Package

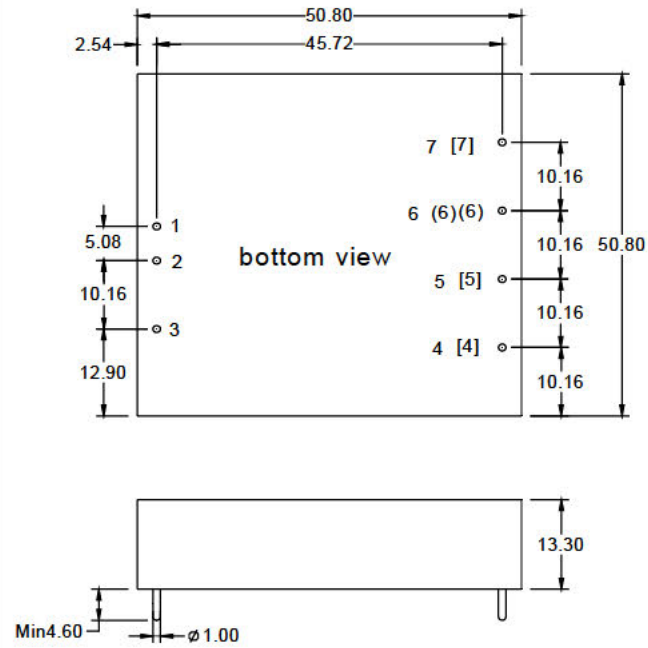

Units: mm
Pin diameter tolerances: $\pm 0.1\text{mm}$
General Tolerance: $\pm 0.5\text{mm}$

PIN CONNECTIONS

Pin	Single output	Dual output
1	+Vin	+Vin
2	-Vin	-Vin
3	CTL	CTL
4	TRM	TRM
[4]	/	/
5	-Vout	-Vout
[5]	/	/
6	+Vout	/
(6)	/	Com
[6]	/	/
7	/	+Vout
[7]	/	/

MODEL SELECTION

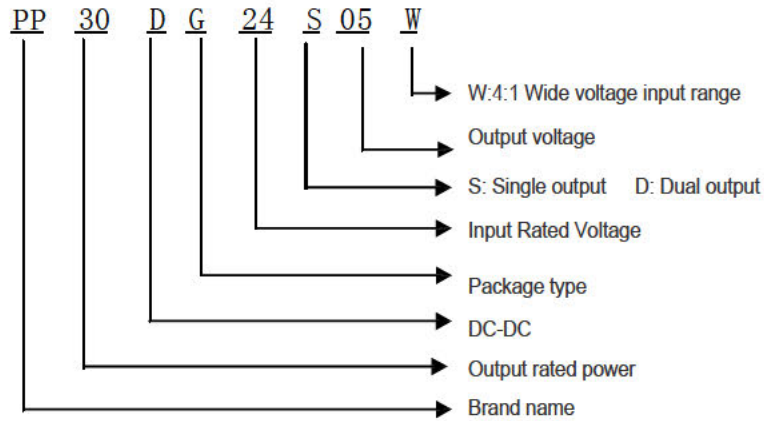

RECOMMEND CIRCUIT

Single Output

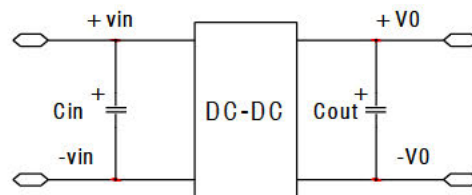

RECOMMEND CIRCUIT

Dual Output:

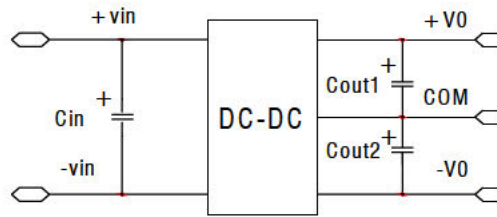

- Add input capacitance C_{in} is helpful to improve the electromagnetic compatibility, recommend C_{in} use 47 uF-100uF of the electrolytic capacitors.
- If the module connect to the digital circuits, please add the C_{out} , C_{out1} , C_{out2} .
- If C_{out} , C_{out1} , C_{out2} value is too high or lower ESR, it will cause the module instable,
- The recommended value of C_{out} , C_{out1} , C_{out2} should be 100 uF/A, the current here means the output current.

Trim application & Trim Resistance

Raise the output Voltage

Down the output voltage

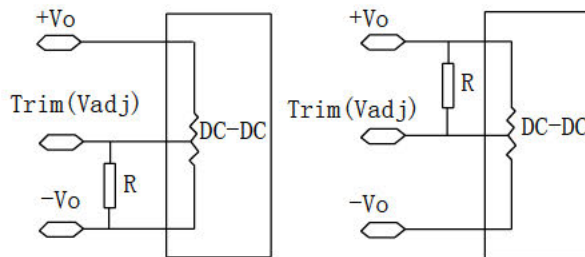

- In dual and triple output modules, this application can just used in the main load(auxiliary road change together with the main load)

USING ATTENTIONS

- Module will cause irreversible damage when in the state of the input reverse polarity.
- Module will cause irreversible damage when in the long-term overload conditions.
- Module will cause irreversible damage when out of the maximum input voltage range.