

DC/DC Converter

PNV25-XXSXXA3NT Series

Typical Feature

- ◆ Fixed Input Voltage, isolated & unregulated, output Power 0.25W
- ◆ Efficiency up to 82%(Typ.)
- ◆ Mini SMD package, international standard pin out
- ◆ Isolation Voltage 3000VDC
- ◆ Operating Temperature: -40°C to +105°C
- ◆ No-load input current as low as 5mA
- ◆ Plastic case with flame class UL94-V0



Test condition: Unless otherwise specified, all the parameters in this data sheet are tested at rated input voltage and rated load (pure resistance load), ambient temperature 25°C.

Application Filed

This series products are widely used in the instrumentation, communication, pure digital circuits, general low-frequency analog circuits, relay drive circuits and data switching circuits, etc.

Typical Product List

Certificate	Part No	Input Voltage Range (VDC)		Output Specification		Input current @rated voltage (mA) Type.		Max capacitive load	Ripple& Noise 20MHz mVp-p		Efficiency @full load Rated input (%)	
				Voltage (VDC)	Current (mA)				Max	Typ.	Min	Typ.
		Rated	Range		Max/Min	Full load	No load	uF	Max	Typ.	Min	Typ.
-	PNV25-05S05A3NT	5	4.5-5.5	5	50/5	56	5	2400	75	40	80	82

Note: The ripple and noise are tested by the twisted pair method.

Input Specifications

Item	Operating Condition	Min.	Typ.	Max.	Unit
Input Inrush Voltage (1 Sec Max)	3.3Vdc Input	-0.7	--	7	Vdc
	5Vdc Input	-0.7	--	9	
	9Vdc Input	-0.7	--	12	
	12Vdc Input	-0.7	--	18	
	15Vdc Input	-0.7	--	21	
	24Vdc Input	-0.7	--	30	
Input filter type		Capacitor Filter			
Hot plug		Unavailable			

Output Specification

Item	Operating Condition	Min.	Typ.	Max.	Unit	
Output Power		0.025	--	0.25	W	
Output Voltage Accuracy		Refer to the Output Voltage Deviation Curve (Figure 1)				
Line Regulation	Input voltage $\pm 1\%$	3.3Vdc output	--	--	1.5	%
		Others output	--	--	1.2	
Load Regulation	10%-100% load	3.3Vdc output	--	15	20	%
		Others output	--	10	15	
Temperature Drift Coefficient	100% load	-	-	± 0.03	%/°C	
Short Circuit Protection	Continuous, Self-recovery					

General Specifications

Item	Operating Condition	Min.	Typ.	Max.	Unit
Switching Frequency	Full load @ rated input	--	330	--	KHz
Operating Temperature	Refer to the temperature derating curve (figure 2)	-40	--	105	°C
Storage Temperature	-	-55	--	125	
Case Temperature Rise	Operating at 25°C	--	30°K	--	
Pin soldering Temp.	1.5mm from the case, 10 Sec.	--	--	300	
Reflow Temperature	Peak temperature $T_c \leq 250^\circ\text{C}$, the maximum time 60S above 217°C				
Storage Humidity	No condensation	5	--	95	%RH
Isolation Voltage	Input-output, 1 minute, leakage current $1 < \text{mA}$	3000	--	--	VDC
Insulation Resistance	Input-output @ 500VDC	1000	--	--	MΩ
Isolation Capacitor	Input-output, 100KHz/0.1V	-	20	-	PF
MTBF	MIL-HDBK-217F@25°C	3500	--	--	K hours
Case Material	Plastic in Black, flame class UL94V-0				
Unit Weight	1.4g (Typ.)				
Cooling Method	Natural air				
Unit package dimensions	L x W x H	12.70X11.00X7.13 mm		0.500X0.433X0.281 inch	

EMC Performance

EMI	CE	CISPR32/EN55032 CLASS B (with Recommended EMC Circuit)
	RE	CISPR32/EN55032 CLASS B (with Recommended EMC Circuit)
EMS	ESD	IEC/EN61000-4-2 Air ± 8kV, Contact ± 6kV perf.Criteria B

Mechanical dimensions

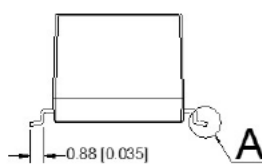
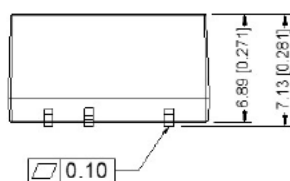
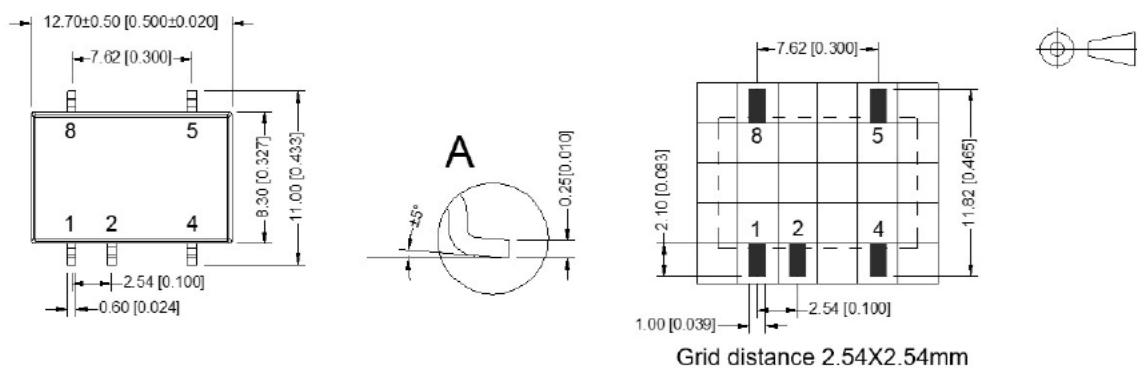

Pin function	
No.	Function
1	-Vin
2	+Vin
4	GND
5	+Vo
8	NC

NC should not connect to any circuit

Note:
Unit: mm[inch]
Pin section tolerance: ± 0.10 [0.004]
General tolerance: ± 0.25 [0.010]

Note: Please take the pin definition on the product label as the right one which is different than the one defined in this data sheet.

Ripple & Noise Test Instructions (Twisted Pair Method, 20MHz Bandwidth)

1) Ripple noise test need 12# twisted pair cables, an oscilloscope which bandwidth should be set to 20MHz, 0.1uF polypropylene capacitor and 10uF high-frequency low-resistance electrolytic capacitor are connected in parallel with the probes (100M bandwidth). The oscilloscope should be set at the Sample Mode.

2) The output ripple noise test diagram is shown on the right. The converter output connects to the electronic load by the jig with cables which size should be defined according to the output current value. The twisted pair (length 30cm±2 cm) should be connected in parallel with the load, the location is as close as possible to the output pins or terminals. The test can be started after input power on.

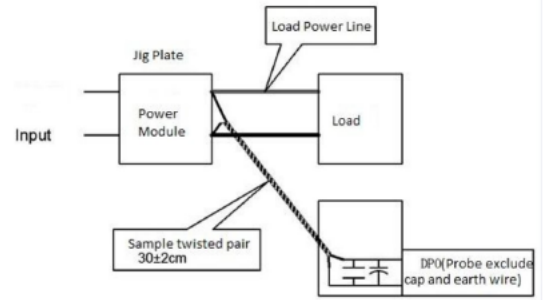

Product Performance Curves

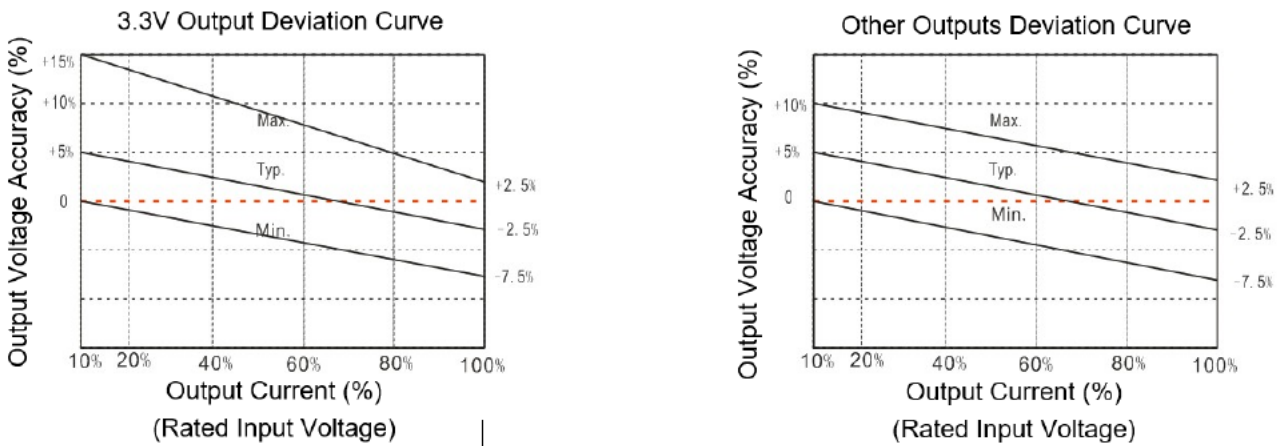

Figure 1

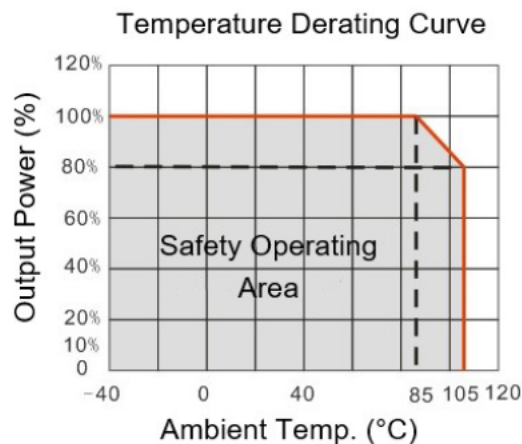

Figure 2

Recommendation for Application

1. Requirement for Output load

The maximum capacitive load of the product was tested at the Rated full load. The converter may not start or be damaged if the capacitor exceeds this value.

2. Recommended typical circuit

To effectively decrease the input and output ripple and noise, a capacitor filter should be connected at the input and output as the application circuit shown in the figure below. The suitable filter capacitors should be chosen as the recommended capacitive load values in Table 1. The converter could not start if the capacitance is too big.

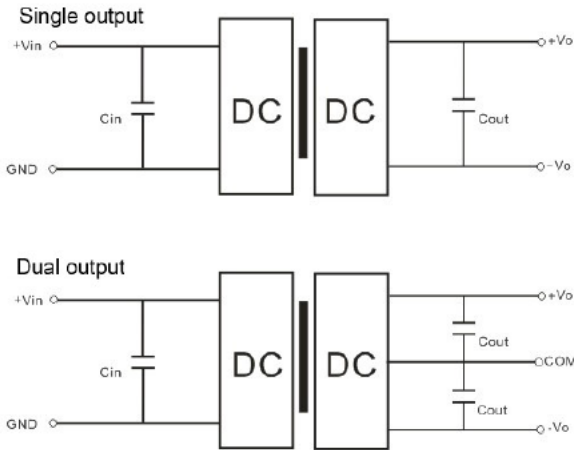

Recommended capacitive load values (Table 1)

Vin (Vdc)	Cin	Single Vout (Vdc)	Cout (µF)	Dual Vout (Vdc)	Cout (µF)
5	10µF/16V	3.3	10µF/16V	±3.3	4.7µF/16V
12	2.2µF/25V	5	10µF/16V	±5	4.7µF/16V
15	2.2µF/25V	9	2.2µF/25V	±9	2.2µF/25V
24	1µF/50V	12	2.2µF/25V	±12	1µF/25V
--	--	15	1µF/25V	±15	1µF/16V
--	--	24	1µF/50V	±24	0.47µF/50V

3. Recommended EMC Circuit

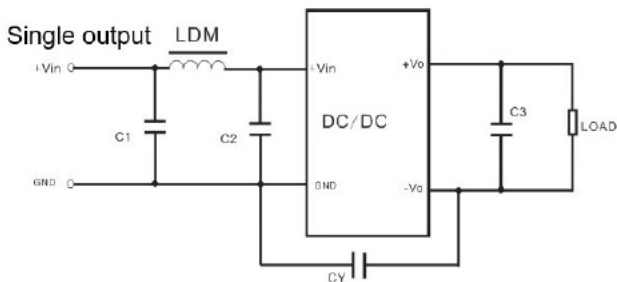

Input voltage		5VDC	12/15/24VDC
EMI	C1/C2	4.7µF/16V	4.7µF/50V
	CY	270pF/2KV	270pF/2KV
	C3	Refer to Cout in Table 1	
	LDM	6.8 µ H	6.8 µ H

4. Output voltage regulation and overvoltage protection

The simple solution to achieve the output regulated voltage, over voltage and over current protections is to connect a linear regulator with overheat protection at input or output, and a capacitor filter connected in parallel as below circuit. Filter capacitive value recommended see table 1, Linear regulator should be chosen according to the actual voltage & current for operating. Or Aipu NW series products are recommended instead.

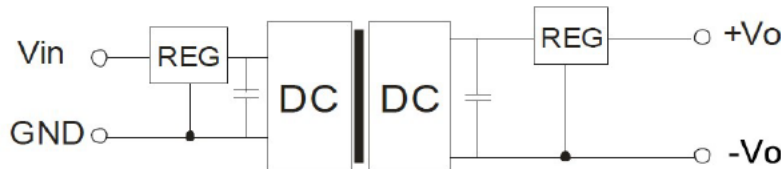

Packing Information

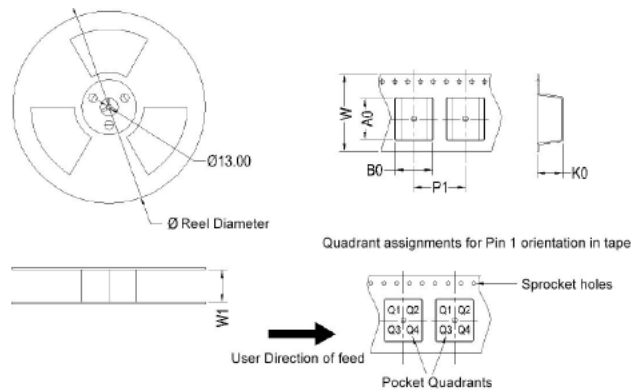
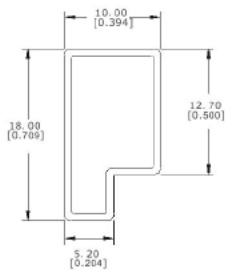

Note:
Unit:mm(inch)
General tolerance:±1.50[±0.059]
Single tube packing qty:39pcs
Carton packing qty:3120pcs
Size of single tube:525x18x10mm
Size of carton:542x110x155mm

Device	Package Type	PIN	SPO	Reel Diameter (mm)	Reel Width W1(mm)	A0 (mm)	B0 (mm)	K0 (mm)	P1 (mm)	W (mm)	PIN1 Quadrant
PNV25-XXSXXANT	SMD	5	500	330	24.5	13.1	11.7	7.5	18.0	24	Q1

Tube packing

Reel packing(500pcs/Reel)

Application Notice

- 1.This product cannot be used in parallel, and it does not support hot-plugging.
- 2.The product performance in this manual cannot be guaranteed if it works at a lower load than the minimum load condition.
3. All values or indicators in this manual had been tested based on Aipupower test specifications.