

### Typical Features

- ◆ Ultra-wide input voltage range 250-1500VDC( 6:1)
- ◆ Input anti-reverse, under voltage protection
- ◆ Output short circuit, over-current, over-voltage protection
- ◆ Input/Output Isolation Voltage 4000VAC
- ◆ Input voltage up to 1700VDC (transient, duration 2S)
- ◆ High efficiency, high reliability, low ripple
- ◆ Applied for Photovoltaic, high-voltage DC Conversions
- ◆ Operating Temperature: -40°C~+85°C
- ◆ Industrial grade design, international standard size



### Application Field

**PBK150-800SXXGA1D6 Series** is a 250-1500VDC ultra-high voltage input high efficiency and high reliability DC-DC switching voltage regulator power module, which can be widely used in photovoltaic power generation and high voltage frequency conversion and other applications, to provide stable working voltage for load equipment, and its own multiple protection functions can improve the safety performance of the power supply and load when the module power supply is abnormal. This series of products must refer to the recommended circuit when the electromagnetic compatibility is relatively harsh environment.

### Typical Product List

Product model	Output power (W)	Output voltage and current		Output efficiency 800VDC %/TYP	Maximum capacitive load (u F)
		voltage (V)	current (mA)		
		PBK150-800S24GA1D6	150	24	6250
PBK150-800S28GA1D6	28	5360		89%	1500
PBK150-800S32GA1D6	32	4688		90%	1000
PBK150-800S35GA1D6	35	4286		90%	1000

Note 1: Due to limited space, the above is only a partial list of products, if you need products other than the list, please contact our sales department.

Note 2: The typical value of output efficiency is based on the product full load aging for half an hour.

Note 3: The fluctuation range of full-load efficiency (% ,TYP) in the table is  $\pm 2\%$ , and the full-load output efficiency is equal to the total output power divided by the input power of the power module.

### Input Specification

Item	Operating Condition	Min.	Typ.	Max.	Unit
Input Voltage Range	--	250	800	1500	VDC
		Please refer to Input Voltage Dearthng Curve at Back			
Input Current	250VDC@75%Load	--	--	800	mA
	800VDC@100%Load	--	--	400	

	1500VDC@100%Load	--	--	300	
Input Under-Voltage Protection	Undervoltage protection start point	130	--	190	VDC
	Undervoltage protection release point	160	--	220	
Input no-load Current	Output no-load	--	--	--	mA
External Fuse Recommend	--	4A/1500VDC Slow fusing, necessary			

### Output Specification

Item	Operating Condition	Min.	Typ.	Max.	Unit
Voltage Accuracy	0%~100%Load	--	±2.0	±3.0	%
Minimum Load	Full Input voltage range	10	--	--	
Line Regulation		--	±1.0	±1.5	
Load Regulation	20%~100% nominal load	--	±2.0	±3.0	
Ripple & Noise	20MHz bandwidth (peak peak value)	--	--	300	mV
Coefficient of temperature drift	--	--	±0.03	--	%
Turn On Delay Time	Room temperature @ output full load	--	3000	--	mS
Power off holding time	Normal temperature @ output full load	800VDCinput	--	50	
		1500VDCinput	--	50	--
Power-on overshoot	0%~100%load	--	--	10	%
Dynamic response to overshoot amplitude	25%-50%-25%	--	±5.0	±6.0	
Dynamic response recovery time	50%-75%-50%	--	--	500	
Output protection	Overcurrent	Full input voltage range	≥110%Io, Hiccup, Self recovery		
	Overvoltage		Feedback clamp limit		
	Short circuit		Continuous @ Hiccup		

### General Specification

Item	Operating Condition	Min.	Typ.	Max.	Unit	
Isolation Voltage	Input-Output	Test for 5 seconds, leakage current ≤5mA	4000	--	--	VAC
	Input-PE	Test for 5 seconds, leakage current ≤5mA	4000	--	--	
Insulation Resistance	Input-Output	500VDC	--	100	--	MΩ
Operating temperature	--	-40	--	+85	°C	
	Perform temperature derating based on the temperature derating curve. For the derating curve, see the following (product feature curve)					
Storage Temperature	--	-40	--	+105		

Casing temperature rise	Ta=30°C@ Output 100% load	--	54	--	
Storage humidity	--	--	--	95	%RH
Welding temperature	Wave soldering welding	260±5°C, time5-10S			
	Hand welding	400±10°C, time4-10S			
Switching frequency	--	--	65	--	KHz
altitude	--	--	--	2000	m
Mean time between failure	--	SR-332@25°C>250000H			

**Physical Specification**

Case Material		Plastic Case	
Package Dimension	Horizontal package	201.0X70.0X42.0mm	
Product Weight		550g	
Cooling method		Free air convection	

**Design Reference**

Output voltage	FUSE
28V	4A/1500DC
24V	Necessary

**EMC Peripheral Recommended Circuit**

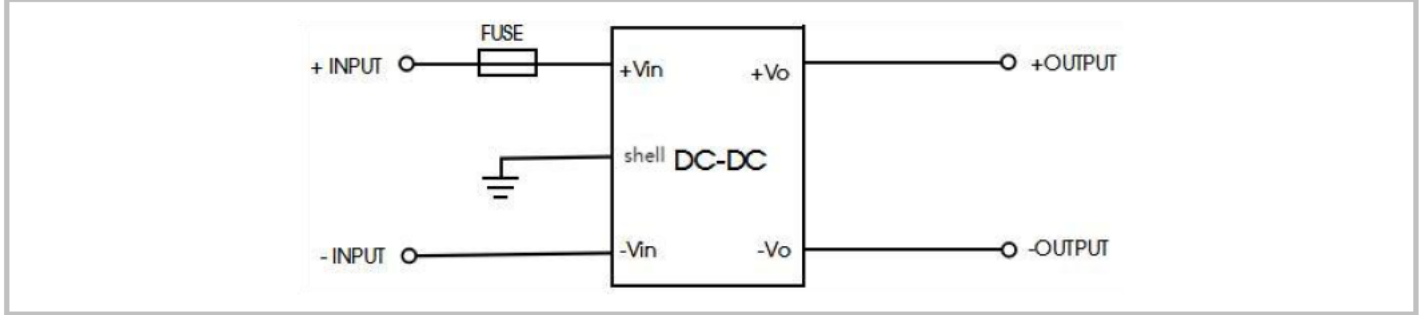

Component bit number and name	Effect	Recommended value	Remark
FUSE - (Safety tube)	If the module is abnormal, it is blown off	Select according to the actual input current of the customer	Must add

Package Size and Pin Function Diagram

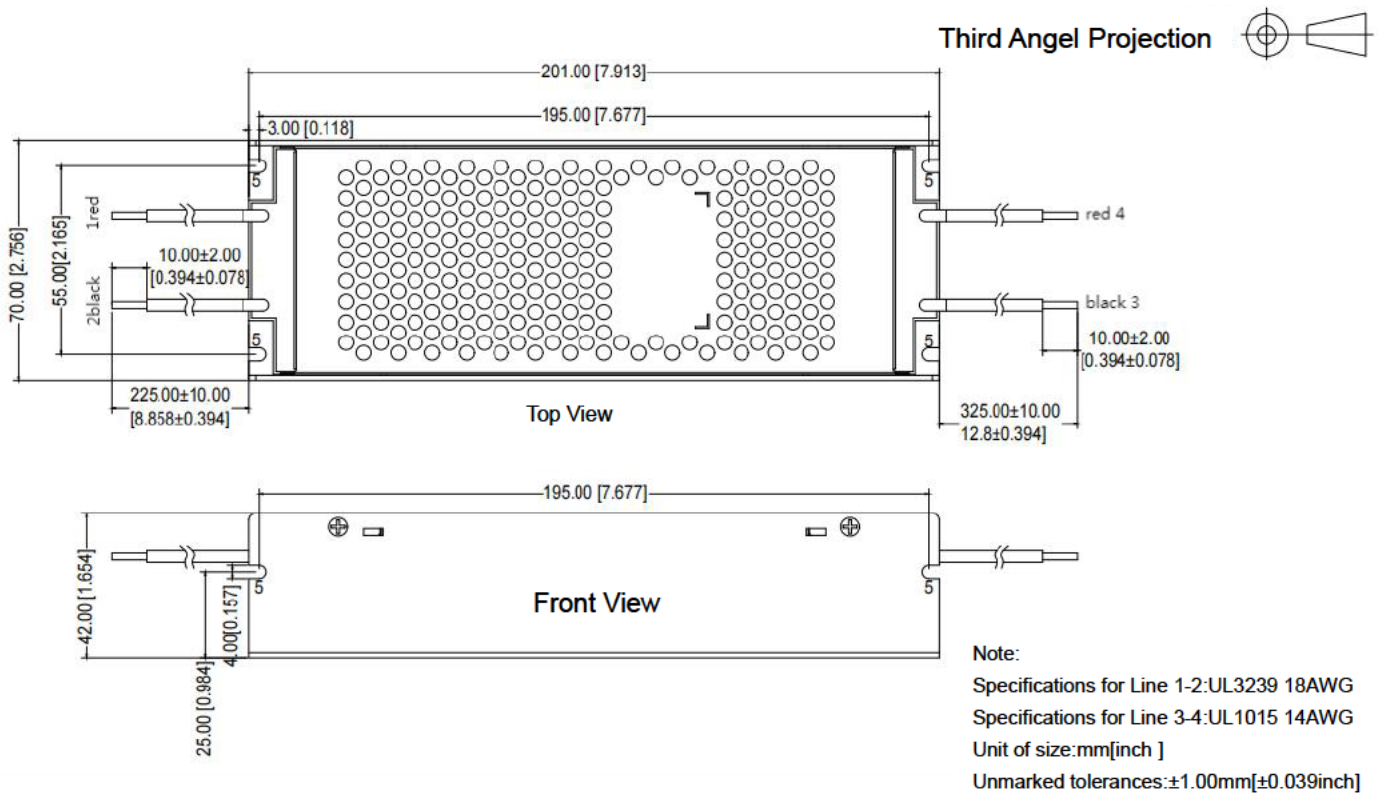

Pin	1	2	3	4	5
Single (S)	+Vin	-Vin	-Vo	+Vo	PE

Package description

Package code	L *W *H	
GA1D6	201.0X70.0X42.0 mm	7.906X2.750X1.656 inch

Ripple & Noise Test: (Twisted Test Method 20MHz bandwidth)

Test method:

1. Ripple noise is connected using 12# twisted pair cable, the oscilloscope bandwidth is set to 20MHz, 100M bandwidth probe, and 0.1uF polypropylene capacitor and 10uF high frequency low resistance electrolytic capacitor are connected in parallel on the probe end, and the oscilloscope sampling uses Sample sampling mode.

2. Output ripple noise test diagram:

Connect the power input end to the input power supply, and the power output is connected to the electronic load through the fixture board. The test is performed using a 30cm ± 2 cm sampling line to directly sample from the power output port. The power line selects the corresponding wire diameter with insulated wire according to the output current.

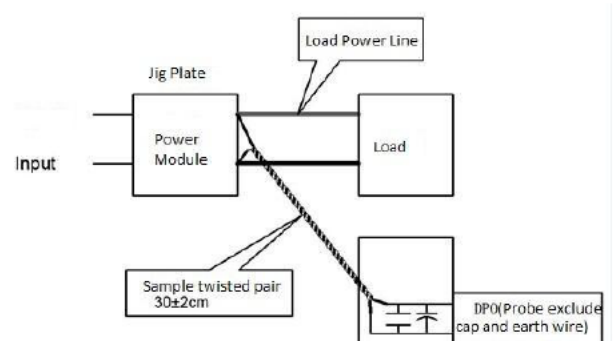

Product characteristic curve

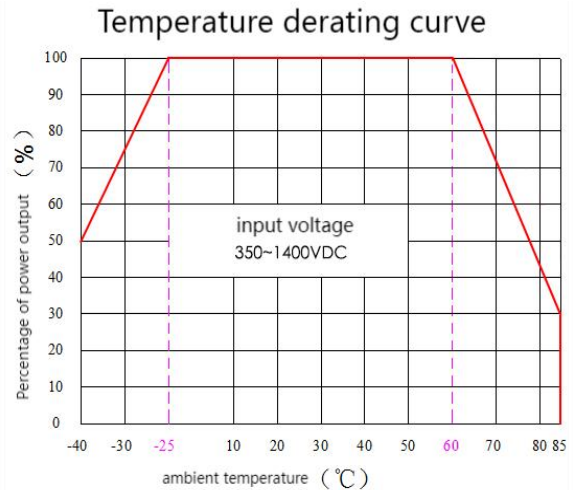
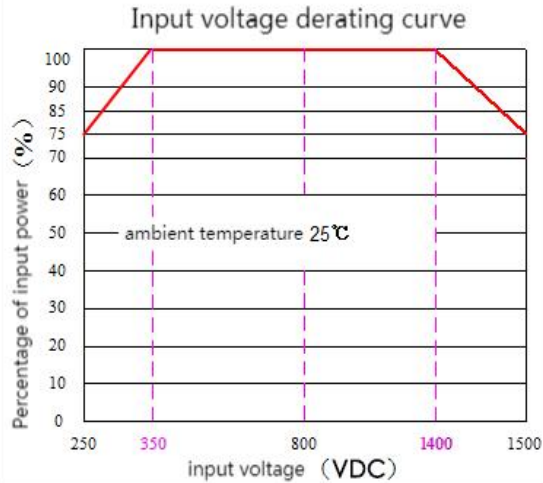

Note:

1. The product should be used within the specification range, otherwise it will cause permanent damage to the product;
2. The product input terminal must be connected to a fuse;
3. If the product works below the minimum required load, it cannot be guaranteed that the product performance meets all the performance indicators in this manual;
4. If the product works beyond the product load range, it cannot be guaranteed that the product performance meets all the performance indicators in this manual;
5. Unless otherwise specified, the above data are measured at  $T_a=25^{\circ}\text{C}$ , humidity<75%, input nominal voltage and output rated load (electronic load);
6. All the above index test methods are based on our company's standards;